

# GREENER MALLS



RDF Green Design

Rick Shanor, Devang Patel, Filip Gzella

# Outline

- We have developed a plan to create an energy independent, environmentally friendly mall
  - PV Solar
  - Geothermal Heating
  - Grass Roof
  - Grey Water System
  - Biodiesel Generator
  - Piezoelectric Panels
  - Environmental Theme

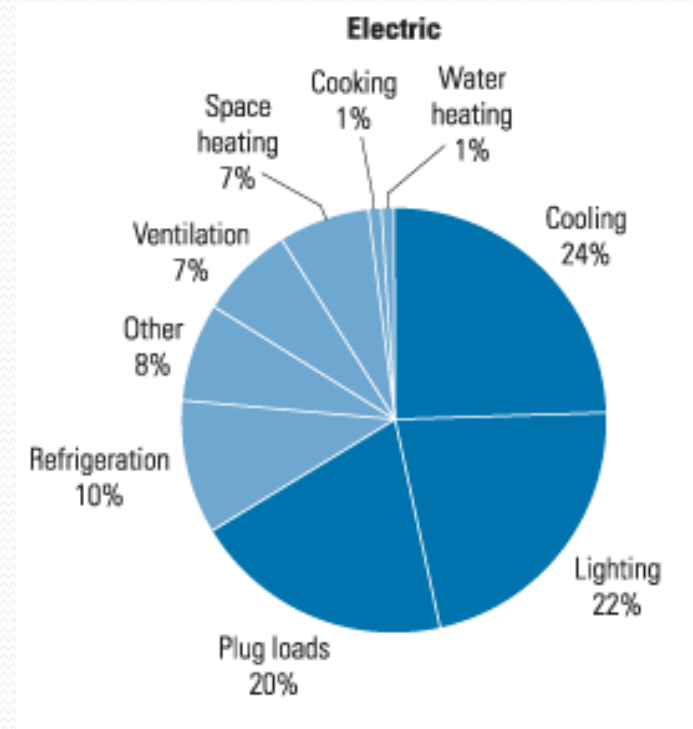

# PV Solar Power: Parking Lot

- \$3.50-4.10 per watt
- Expected payoff in 10 years

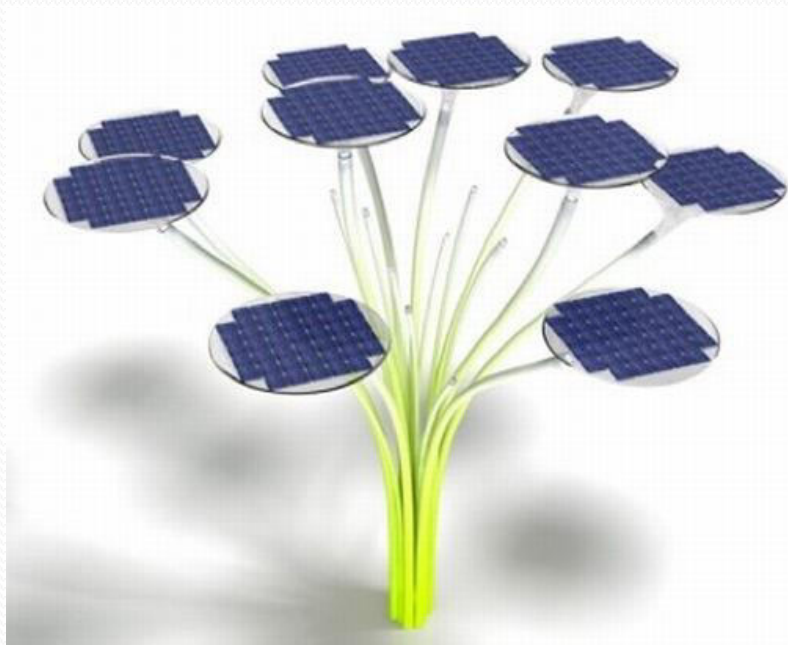

# PV Solar Power: Roof Top

- \$2.50-3.10 per watt
- Expected payoff in 7 years
- 10% Government tax cut for Solar Panel use



# Geothermal Heating/Cooling

- Expected payoff in 5-10 years
- Expensive up-front cost
- Government tax break of 10%

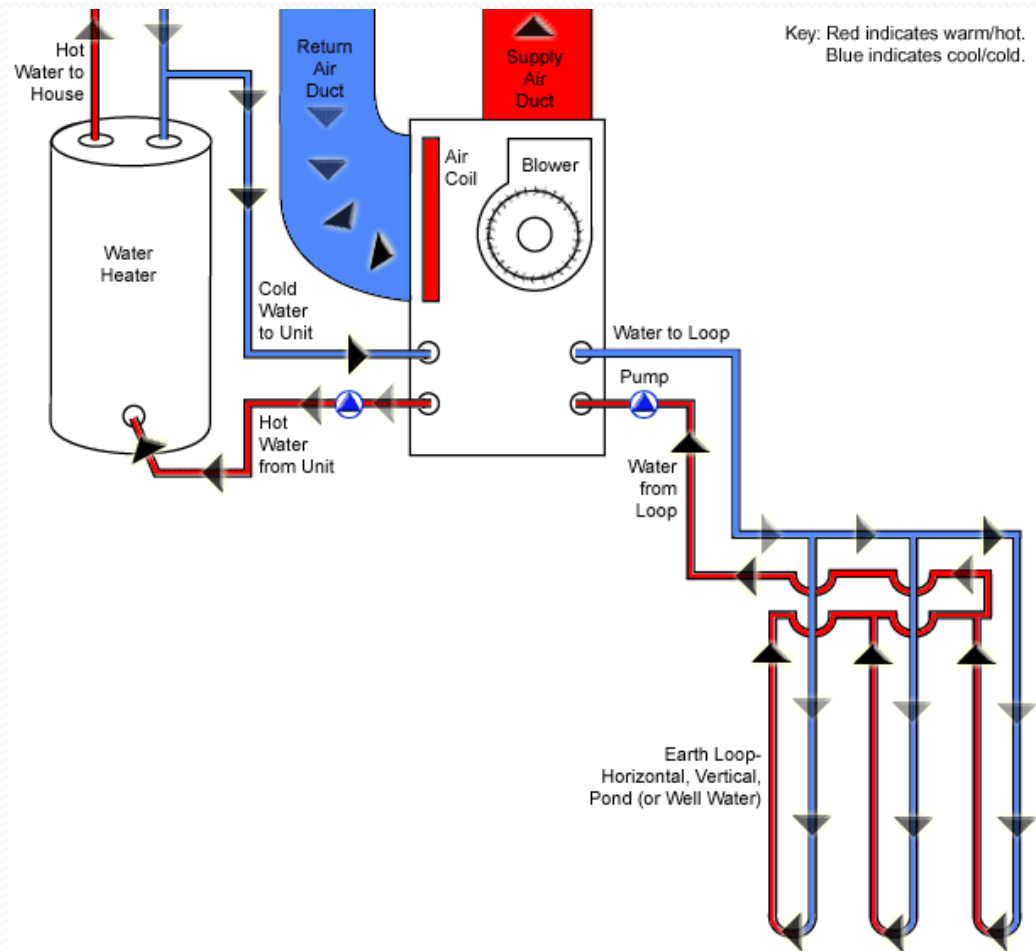

# Grass Roof

- Proven to reduce heating/cooling costs by more than 50%
- Cost of \$15 per square foot
- Work by capturing and diffusing solar rays, helping keep the mall at a constant temperature



# Grey Water System

- Recycle rainwater and sink water into toilet and garden watering system
- Approximately 40% decrease in water needs, depending on location



# Biodiesel Generator

- Use oil waste from food court restaurants to power generator during night hours (convert to biodiesel)





# Piezoelectric

- Average person generates 3Watts climbing stairs
- 20,000+ people visit a mall each day
- Implement in parking lots, entrances, and all areas of high traffic



# Green Stores

- Stores receive lease discounts for incorporating renewable technologies in their stores, for example:
  - Electronic Receipts
  - Green Shopping Bags
  - Providing oil for Biodiesel generator
  - Sponsor green companies



# Customer Awareness

- Walking path on roof outlining GREEN systems
- Mall Certification for stores which incorporate the most green technologies

